



INSTRUCTION BULLETIN

No. 340880
Machine: M30
Published: 07-2008
Rev. 00

NOTE: DO NOT DISCARD the Parts List from the Instruction Bulletin. Place the Parts List in the appropriate place in the machine manual for future reference. Retaining the Parts List will make it easier to reorder individual parts and will save the cost of ordering an entire kit.

NOTE: Numbers in parenthesis () are reference numbers for parts listed in Bill of Materials.

Installation instructions for **kit number 9004071**

SYNOPSIS:

This kit contains the parts needed to install a vacuum wand kit on M30 machines.
Please follow step-by-step instructions.

SPECIAL TOOLS / CONSIDERATIONS: NONE

(Estimated time to complete: 1 hour)

PREPARATION:

1. Park the machine on a clean level surface, turn off the machine, remove the key, and set the parking brake.

FOR SAFETY: Before leaving or servicing machine, stop on level surface, turn off machine, set parking brake, and remove key.

INSTALLATION:

1. Drill six holes into the top of the recovery tank cover. Refer to Fig. 4 for sizes and locations.
2. Use four plastic rivets (2) to install the bag (1) onto the recovery tank cover. Refer to Fig. 3.
3. Use a hex screw (9) and three flat washers (8) to install each finger grip clip (7) onto the recovery tank cover. Refer to Fig. 3.
4. Install the plunger (10) into the hose assembly (4). The ball end of the plunger must be oriented toward the outside of the cuff. Refer to Fig. 1.

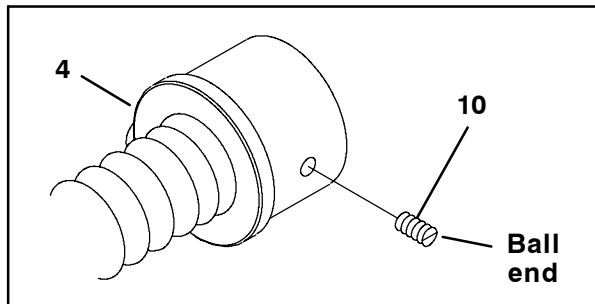

FIG. 1

5. Install the squeegee shoe (5) onto the wand nozzle (6). Refer to Fig. 3.

6. Insert the hose (4), wand nozzle (6), and vacuum wand tubes (3) into the bag (1) and insert the ends of the vacuum wand tubes into the finger grip clips (7). Refer to Fig. 2 and Fig. 3.



FIG. 2

7. Use the vacuum wand to clean. Refer to the Operation Manual for instructions how to assemble and operate the vacuum wand.

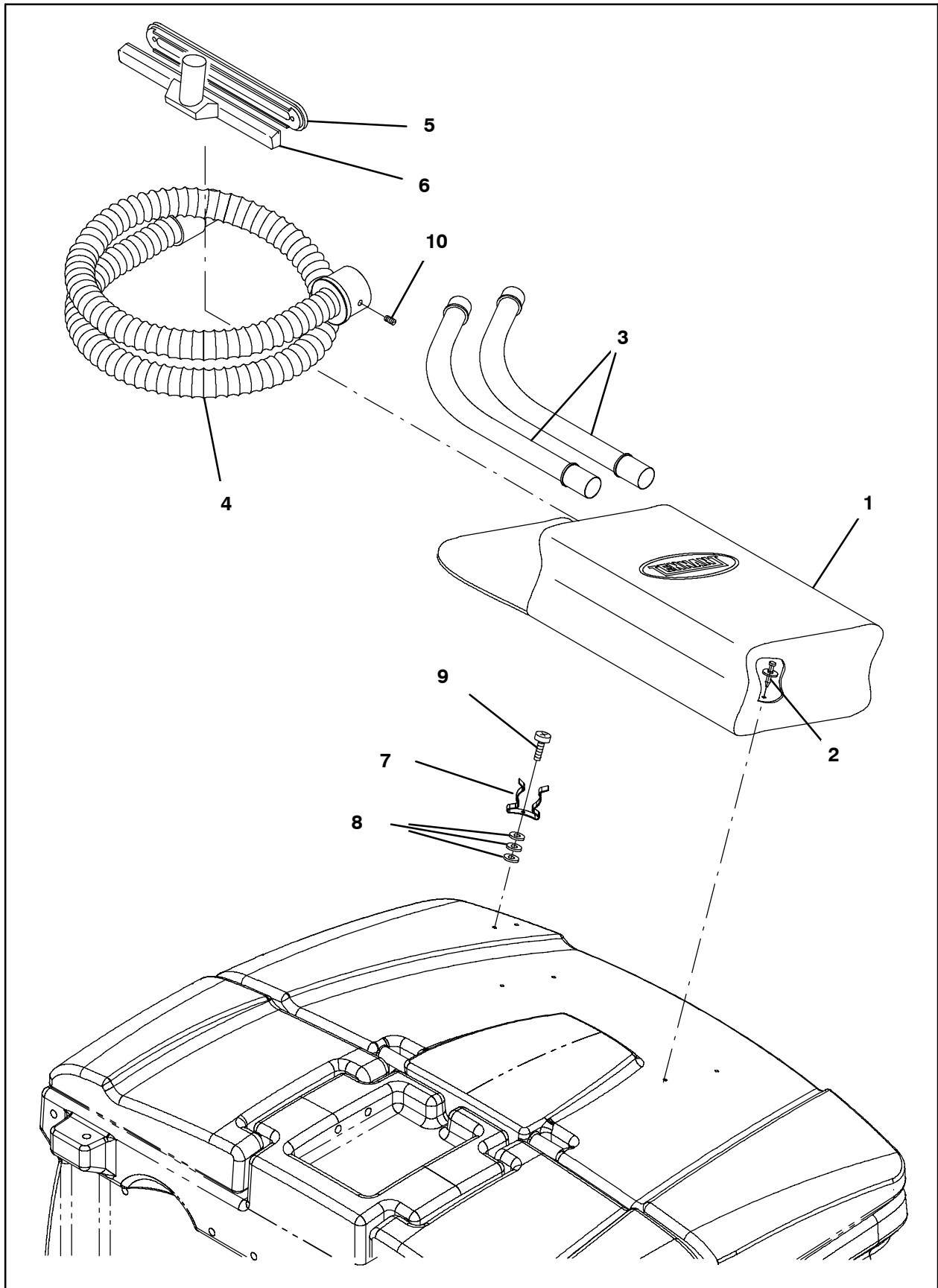

FIG. 3

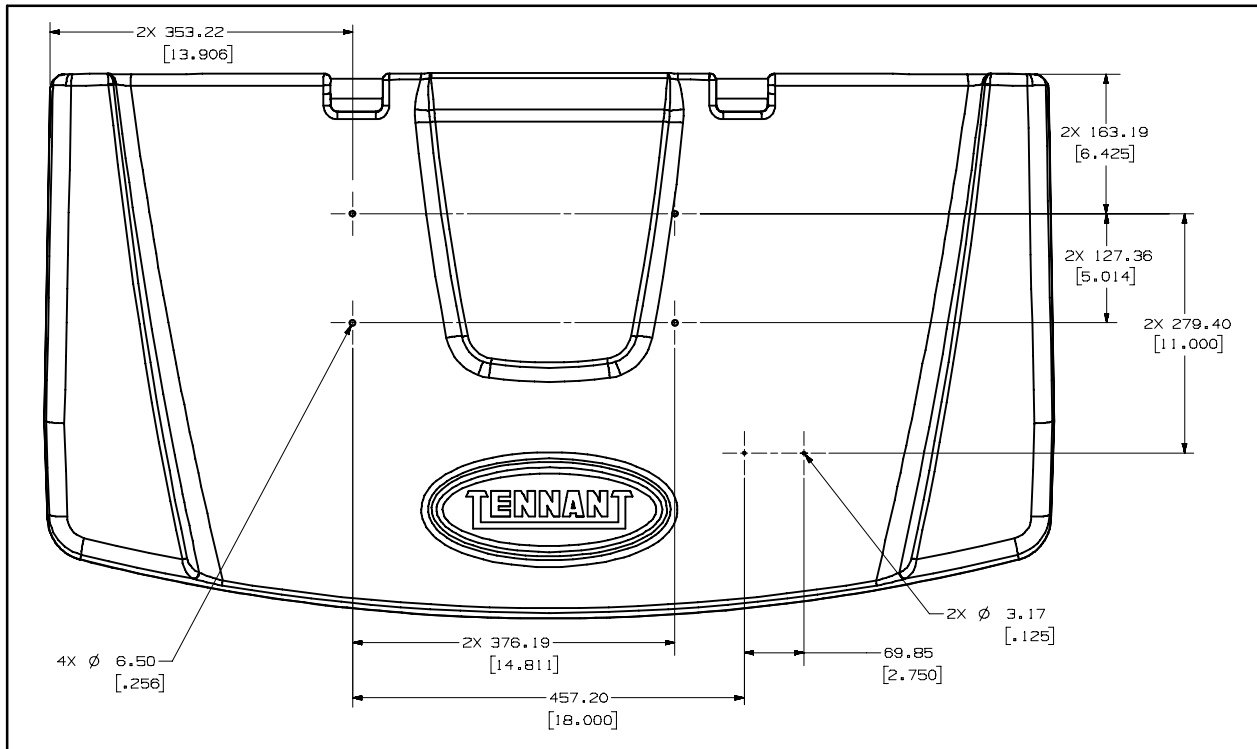

FIG. 4

Bill of Materials for Wand Kit, Vacuum, Sqge, CI [M30] - 9004071

Ref.	Tennant Part No.	Description	Qty.
▽	9004071	Wand Kit, Vacuum, Sqge, CI [M20]	1
▲	1 65580	Bag, Power	1
▲	2 72968	Rivet, Plstc, .250 X 0.898	4
▲	3 63448	Tube, Wand, Vacuum, Metal [1pick=1box]	1
▲	4 69657	Hose Assy, W/2cuff, 1.5d 84l [Vacwand]	1
▲	5 63430	Shoe, Plstc, Sqge, 14.0	1
▲	6 63451	Nozzle, Wand, Plstc, 14.0lg	1
▲	7 67004	Clip, Grip, Finger, 1.00-1.88d White, Vyl	2
▲	8 19064	Washer, Flat, #06	6
▲	9 55845	Screw, Hex, M5 X 0.8 X 16, Fmg	2
▲	10 69659	Plunger	1

TENNANT COMPANY
P. O. Box 1452
Minneapolis, MN 55440-1452